

REVISIONS			
LTR	DESCRIPTION	DATE (YR-MO-DA)	APPROVED
A	Drawing updated to reflect current requirements. - ro	01-03-30	R. MONNIN

THE ORIGINAL FIRST SHEET OF THIS DRAWING HAS BEEN REPLACED.

REV																				
SHEET																				
REV																				
SHEET																				

REV STATUS	REV	A	A	A	A	A	A	A	A	A	A	A	A	A						
OF SHEETS	SHEET	1	2	3	4	5	6	7	8	9	10	11								

PMIC N/A	PREPARED BY RICK C. OFFICER	<p align="center">DEFENSE SUPPLY CENTER COLUMBUS COLUMBUS, OHIO 43216 http://www.dsccl.dla.mil</p>																	
<p align="center">STANDARD MICROCIRCUIT DRAWING</p> <p>THIS DRAWING IS AVAILABLE FOR USE BY ALL DEPARTMENTS AND AGENCIES OF THE DEPARTMENT OF DEFENSE</p> <p align="center">AMSC N/A</p>	CHECKED BY CHARLES E. BESORE																		
	APPROVED BY MICHAEL A. FRYE	<p align="center">MICROCIRCUITS, LINEAR, PRECISION VOLTAGE REFERENCE, MONOLITHIC SILICON</p>																	
	DRAWING APPROVAL DATE 89-12-28																		
	REVISION LEVEL A		SIZE A	CAGE CODE 67268	5962-89728														
		SHEET 1 OF 11																	

1. SCOPE

1.1 Scope. This drawing describes device requirements for MIL-STD-883 compliant, non-JAN class level B microcircuits in accordance with MIL-PRF-38535, appendix A.

1.2 Part or Identifying Number (PIN). The complete PIN is as shown in the following example:

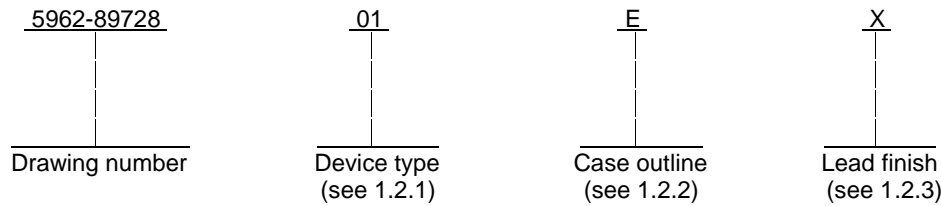

1.2.1 Device type(s). The device type(s) identify the circuit function as follows:

<u>Device type</u>	<u>Generic number</u>	<u>Circuit function</u>
01	AD588S	Pin programmable voltage reference
02	AD588T	Pin programmable voltage reference

1.2.2 Case outline(s). The case outline(s) are as designated in MIL-STD-1835 and as follows:

<u>Outline letter</u>	<u>Descriptive designator</u>	<u>Terminals</u>	<u>Package style</u>
E	GDIP1-T16 or CDIP2-T16	16	Dual-in-line
2	CQCC1-N20	20	Square leadless chip carrier

1.2.3 Lead finish. The lead finish is as specified in MIL-PRF-38535, appendix A.

1.3 Absolute maximum ratings. 1/

Positive supply voltage (+V _S)	+18 V dc
Negative supply voltage (-V _S)	-18 V dc
Power dissipation (P _D) at T _A = +25°C	600 mW
Storage temperature range	-65°C to +150°C
Lead temperature (soldering, 10 seconds)	+300°C
Junction temperature (T _J)	+175°C
Thermal resistance, junction-to-case (θ _{JC})	See MIL-STD-1835
Thermal resistance, junction-to-ambient (θ _{JA})	90°C/W

1.4 Recommended operating conditions.

Positive supply voltage (+V _S)	+15 V dc
Negative supply voltage (-V _S)	-15 V dc
Ambient operating temperature range (T _A)	-55°C to +125°C

1/ All outputs may be shorted to ground.

STANDARD MICROCIRCUIT DRAWING DEFENSE SUPPLY CENTER COLUMBUS COLUMBUS, OHIO 43216-5000	SIZE A	5962-89728
	REVISION LEVEL A	SHEET 2

2. APPLICABLE DOCUMENTS

2.1 Government specification, standards, and handbooks. The following specification, standards, and handbooks form a part of this drawing to the extent specified herein. Unless otherwise specified, the issues of these documents are those listed in the issue of the Department of Defense Index of Specifications and Standards (DoDISS) and supplement thereto, cited in the solicitation.

SPECIFICATION

DEPARTMENT OF DEFENSE

MIL-PRF-38535 - Integrated Circuits, Manufacturing, General Specification for.

STANDARDS

DEPARTMENT OF DEFENSE

MIL-STD-883 - Test Method Standard Microcircuits.
MIL-STD-1835 - Interface Standard Electronic Component Case Outlines.

HANDBOOKS

DEPARTMENT OF DEFENSE

MIL-HDBK-103 - List of Standard Microcircuit Drawings.
MIL-HDBK-780 - Standard Microcircuit Drawings.

(Unless otherwise indicated, copies of the specification, standards, and handbooks are available from the Standardization Document Order Desk, 700 Robbins Avenue, Building 4D, Philadelphia, PA 19111-5094.)

2.2 Order of precedence. In the event of a conflict between the text of this drawing and the references cited herein, the text of this drawing takes precedence. Nothing in this document, however, supersedes applicable laws and regulations unless a specific exemption has been obtained.

3. REQUIREMENTS

3.1 Item requirements. The individual item requirements shall be in accordance with MIL-PRF-38535, appendix A for non-JAN class level B devices and as specified herein. Product built to this drawing that is produced by a Qualified Manufacturer Listing (QML) certified and qualified manufacturer or a manufacturer who has been granted transitional certification to MIL-PRF-38535 may be processed as QML product in accordance with the manufacturers approved program plan and qualifying activity approval in accordance with MIL-PRF-38535. This QML flow as documented in the Quality Management (QM) plan may make modifications to the requirements herein. These modifications shall not affect form, fit, or function of the device. These modifications shall not affect the PIN as described herein. A "Q" or "QML" certification mark in accordance with MIL-PRF-38535 is required to identify when the QML flow option is used.

3.2 Design, construction, and physical dimensions. The design, construction, and physical dimensions shall be as specified in MIL-PRF-38535, appendix A and herein.

3.2.1 Case outline(s). The case outline(s) shall be in accordance with 1.2.2 herein.

3.2.2 Terminal connections. The terminal connections shall be as specified on figure 1.

3.2.3 Logic diagram(s). The logic diagram(s) shall be as specified on figure 2.

STANDARD MICROCIRCUIT DRAWING DEFENSE SUPPLY CENTER COLUMBUS COLUMBUS, OHIO 43216-5000	SIZE A		5962-89728
		REVISION LEVEL A	SHEET 3

3.3 Electrical performance characteristics. Unless otherwise specified herein, the electrical performance characteristics are as specified in table I and shall apply over the full ambient operating temperature range.

3.4 Electrical test requirements. The electrical test requirements shall be the subgroups specified in table II. The electrical tests for each subgroup are described in table I.

3.5 Marking. Marking shall be in accordance with MIL-PRF-38535, appendix A. The part shall be marked with the PIN listed in 1.2 herein. In addition, the manufacturer's PIN may also be marked as listed in MIL-HDBK-103 (see 6.6 herein). For packages where marking of the entire SMD PIN number is not feasible due to space limitations, the manufacturer has the option of not marking the "5962-" on the device.

3.6 Certificate of compliance. A certificate of compliance shall be required from a manufacturer in order to be listed as an approved source of supply in MIL-HDBK-103 (see 6.6 herein). The certificate of compliance submitted to DSCC-VA prior to listing as an approved source of supply shall affirm that the manufacturer's product meets the requirements of MIL-PRF-38535, appendix A and the requirements herein.

3.7 Certificate of conformance. A certificate of conformance as required in MIL-PRF-38535, appendix A shall be provided with each lot of microcircuits delivered to this drawing.

3.8 Notification of change. Notification of change to DSCC-VA shall be required in accordance with MIL-PRF-38535, appendix A.

3.9 Verification and review. DSCC, DSCC's agent, and the acquiring activity retain the option to review the manufacturer's facility and applicable required documentation. Offshore documentation shall be made available onshore at the option of the reviewer.

4. QUALITY ASSURANCE PROVISIONS

4.1 Sampling and inspection. Sampling and inspection procedures shall be in accordance with MIL-PRF-38535, appendix A.

4.2 Screening. Screening shall be in accordance with method 5004 of MIL-STD-883, and shall be conducted on all devices prior to quality conformance inspection. The following additional criteria shall apply:

a. Burn-in test, method 1015 of MIL-STD-883.

(1) Test condition A, B, C, or D. The test circuit shall be maintained by the manufacturer under document revision level control and shall be made available to the preparing or acquiring activity upon request. The test circuit shall specify the inputs, outputs, biases, and power dissipation, as applicable, in accordance with the intent specified in test method 1015 of MIL-STD-883.

(2) $T_A = +125^{\circ}\text{C}$, minimum.

b. Interim and final electrical test parameters shall be as specified in table II herein, except interim electrical parameter tests prior to burn-in are optional at the discretion of the manufacturer.

c. Subgroup 12 test is used for grading and part selection at $T_A = +25^{\circ}\text{C}$.

STANDARD MICROCIRCUIT DRAWING DEFENSE SUPPLY CENTER COLUMBUS COLUMBUS, OHIO 43216-5000	SIZE A		5962-89728
		REVISION LEVEL A	SHEET 4

TABLE I. Electrical performance characteristics.

Test	Symbol	Conditions <u>1/</u> -55°C ≤ T _A ≤ +125°C unless otherwise specified	Group A subgroups	Device type	Limits		Unit
					Min	Max	
Output voltage error	V _{OUT}	Outputs: +10 V, -10 V, T _A = +25°C	1	01,02		±5.0	mV
			12	02		±3.0	
		Outputs: +5.0 V, -5.0 V, T _A = +25°C	1	01,02		±5.0	
			12	02		±3.0	
Symmetry error	S _e	Tracking mode: ±5.0 V, T _A = +25°C	1	All		±1.5	mV
Output voltage drift	dV _O / dT		2,3	01		±6.0	ppm/°C
			12	02		±4.0	
Line regulation	V _{RLN}	<u>2/</u>	1,2,3	All		±200	μV/V
Load regulation	V _{RLD}	+10 V output, 0 mA ≤ I _{OUT} ≤ 10 mA	1,2,3	All		±50	μV/mA
		-10 V output, -10 mA ≤ I _{OUT} ≤ 0 mA				±50	
Supply current	I _{CC}		1,2,3	All		10	mA
Output current	I _{OUT}	Amplifiers A3, A4 <u>3/</u>	1,2,3	All	-10	+10	mA

1/ Unless otherwise specified, +V_S = 15 V dc, -V_S = -15 V dc. Test conditions using +10 V output, +5.0 V and -5.0 V outputs, and -10 V output, with ±5.0 V tracking are as specified on figure 3.

2/ Test conditions:

+10 V output -V_S = -15 V dc, 13.5 V dc ≤ +V_S ≤ 18 V dc

-10 V output +V_S = +15 V dc, -18 V dc ≤ -V_S ≤ -13.5 V dc

±5.0 V output +V_S = +18 V dc, -V_S = -10.8 V dc

+V_S = +10.8 V dc, -V_S = -10.8 V dc

3/ Parameters shall be tested as part of device initial characterization and after design and process change. Parameter shall be guaranteed to the limits specified in table I for all lots not specifically tested.

STANDARD MICROCIRCUIT DRAWING DEFENSE SUPPLY CENTER COLUMBUS COLUMBUS, OHIO 43216-5000	SIZE A		5962-89728
		REVISION LEVEL A	SHEET 5

Device types	01 and 02	
Case outlines	E	2
Terminal number	Terminal symbol	
1	A3 OUT FORCE	NC
2	+V _S	A3 OUT FORCE
3	A3 OUT SENSE	+V _S
4	A3 +IN	A3 OUT SENSE
5	GAIN ADJ	A3 +IN
6	V _{HIGH}	NC
7	NOISE REDUCTION	GAIN ADJ
8	V _{LOW}	V _{HIGH}
9	GND SENSE +IN	NOISE REDUCTION
10	GND SENSE -IN	V _{LOW}
11	V _{CT}	NC
12	BAL ADJ	GND SENSE +IN
13	A4 +IN	GND SENSE -IN
14	A4 OUT SENSE	V _{CT}
15	A4 OUT FORCE	BAL ADJ
16	-V _S	NC
17	---	A4 +IN
18	---	A4 OUT SENSE
19	---	A4 OUT FORCE
20	---	-V _S

NC = No connection

FIGURE 1. Terminal connections.

STANDARD MICROCIRCUIT DRAWING DEFENSE SUPPLY CENTER COLUMBUS COLUMBUS, OHIO 43216-5000	SIZE A		5962-89728
		REVISION LEVEL A	SHEET 6

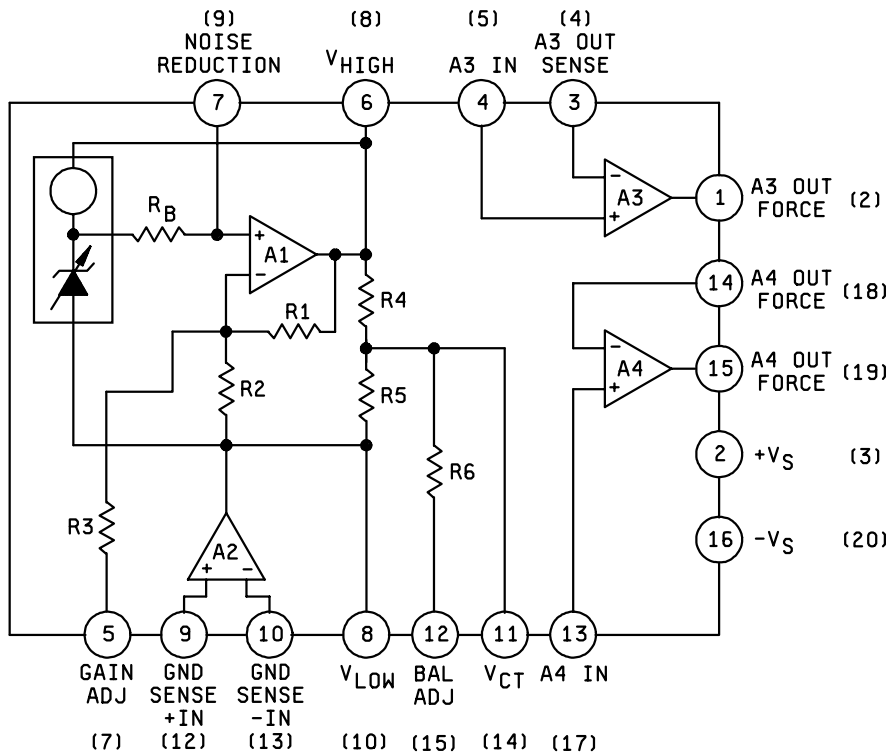

NOTE: Terminal numbers within the parentheses symbol represent the case 2 package.

FIGURE 2. Logic diagram.

STANDARD MICROCIRCUIT DRAWING DEFENSE SUPPLY CENTER COLUMBUS COLUMBUS, OHIO 43216-5000	SIZE A		5962-89728
		REVISION LEVEL A	SHEET 7

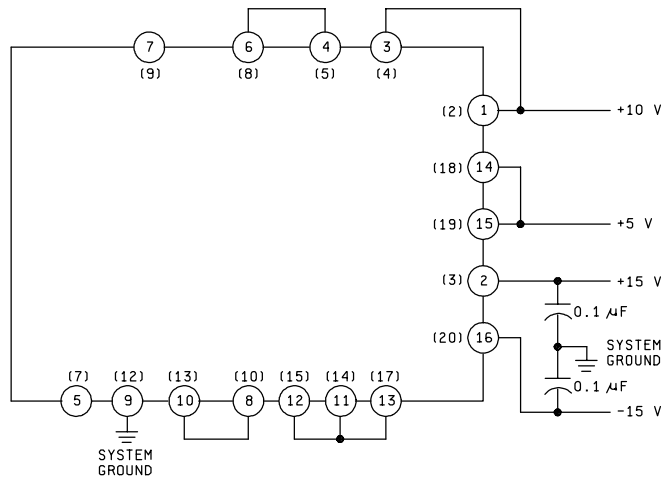

+10 V OUTPUT TEST CONDITIONS

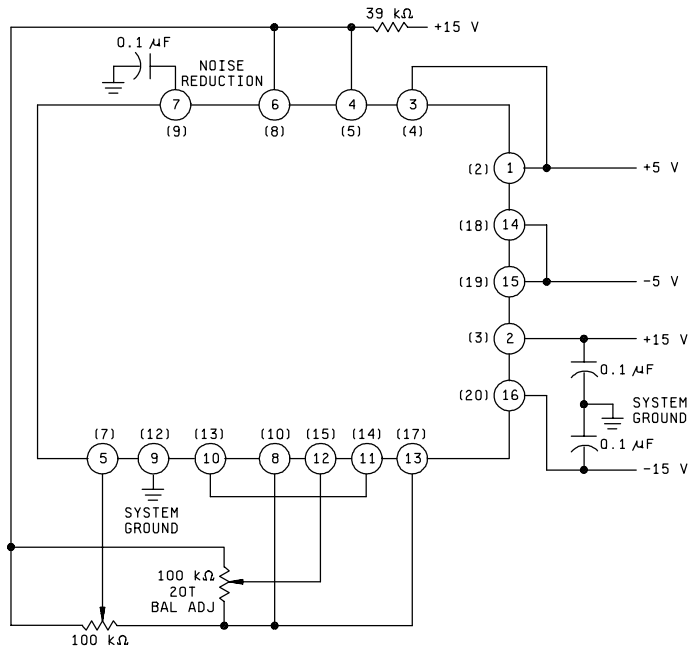

+5 V AND -5 V OUTPUT TEST CONDITIONS

FIGURE 3. Test conditions.

**STANDARD
MICROCIRCUIT DRAWING**
DEFENSE SUPPLY CENTER COLUMBUS
COLUMBUS, OHIO 43216-5000

SIZE
A

5962-89728

REVISION LEVEL
A

SHEET
8

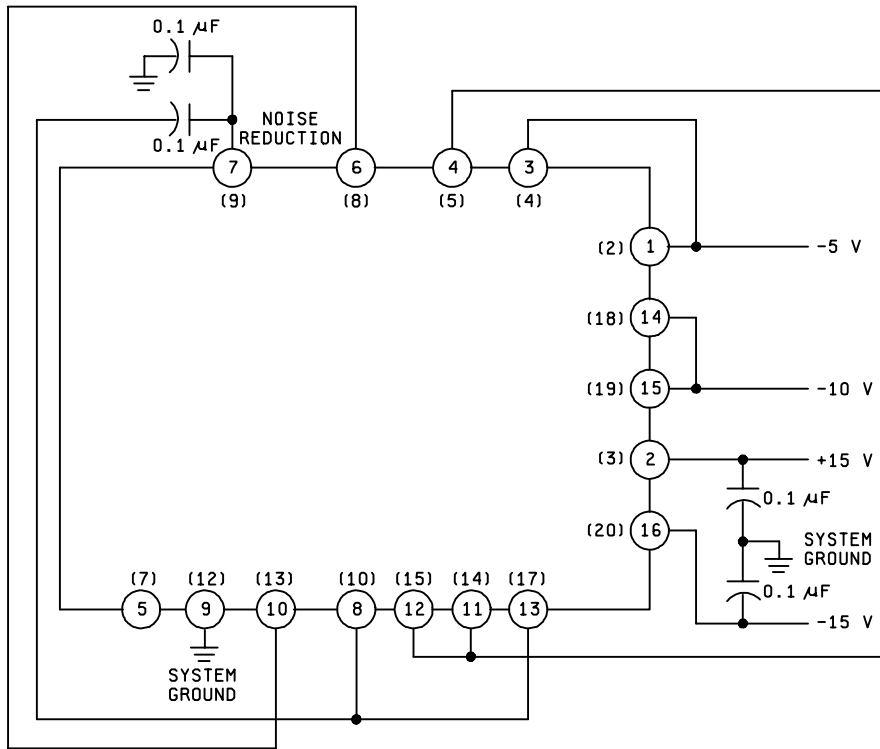

+10 V OUTPUT TEST CONDITIONS

NOTE: Terminal numbers within the parentheses symbol represent the case 2 package.

FIGURE 3. Test conditions – Continued.

STANDARD MICROCIRCUIT DRAWING DEFENSE SUPPLY CENTER COLUMBUS COLUMBUS, OHIO 43216-5000	SIZE A		5962-89728
		REVISION LEVEL A	SHEET 9

TABLE II. Electrical test requirements.

MIL-STD-883 test requirements	Subgroups (in accordance with MIL-STD-883, method 5005, table I)
Interim electrical parameters (method 5004)	1
Final electrical test parameters (method 5004)	1*,2,3,12
Group A test requirements (method 5005)	1,2,3,12
Groups C and D end-point electrical parameters (method 5005)	1

* PDA applies to subgroup 1.

4.3 Quality conformance inspection. Quality conformance inspection shall be in accordance with method 5005 of MIL-STD-883 including groups A, B, C, and D inspections. The following additional criteria shall apply.

4.3.1 Group A inspection.

- a. Tests shall be as specified in table II herein.
- b. Subgroups 4, 5, 6, 7, 8, 9, 10, and 11 in table I, method 5005 of MIL-STD-883 shall be omitted.
- c. Subgroup 12 test is used for grading and part selection at $T_A = +25^\circ\text{C}$.

4.3.2 Groups C and D inspections.

- a. End-point electrical parameters shall be as specified in table II herein.
- b. Steady-state life test conditions, method 1005 of MIL-STD-883.
 - (1) Test condition A, B, C, or D. The test circuit shall be maintained by the manufacturer under document revision level control and shall be made available to the preparing or acquiring activity upon request. The test circuit shall specify the inputs, outputs, biases, and power dissipation, as applicable, in accordance with the intent specified in test method 1005 of MIL-STD-883.
 - (2) $T_A = +125^\circ\text{C}$, minimum.
 - (3) Test duration: 1,000 hours, except as permitted by method 1005 of MIL-STD-883.

5. PACKAGING

5.1 Packaging requirements. The requirements for packaging shall be in accordance with MIL-PRF-38535, appendix A.

STANDARD MICROCIRCUIT DRAWING DEFENSE SUPPLY CENTER COLUMBUS COLUMBUS, OHIO 43216-5000	SIZE A		5962-89728
		REVISION LEVEL A	SHEET 10

6. NOTES

6.1 Intended use. Microcircuits conforming to this drawing are intended for use for Government microcircuit applications (original equipment), design applications, and logistics purposes.

6.2 Replaceability. Microcircuits covered by this drawing will replace the same generic device covered by a contractor-prepared specification or drawing.

6.3 Configuration control of SMD's. All proposed changes to existing SMD's will be coordinated with the users of record for the individual documents. This coordination will be accomplished using DD Form 1692, Engineering Change Proposal.

6.4 Record of users. Military and industrial users shall inform Defense Supply Center Columbus when a system application requires configuration control and the applicable SMD. DSCC will maintain a record of users and this list will be used for coordination and distribution of changes to the drawings. Users of drawings covering microelectronics devices (FSC 5962) should contact DSCC-VA, telephone (614) 692-0544.

6.5 Comments. Comments on this drawing should be directed to DSCC-VA, Columbus, Ohio 43216-5000, or telephone (614) 692-0547.

6.6 Approved sources of supply. Approved sources of supply are listed in MIL-HDBK-103. The vendors listed in MIL-HDBK-103 have agreed to this drawing and a certificate of compliance (see 3.6 herein) has been submitted to and accepted by DSCC-VA.

STANDARD MICROCIRCUIT DRAWING DEFENSE SUPPLY CENTER COLUMBUS COLUMBUS, OHIO 43216-5000	SIZE A		5962-89728
		REVISION LEVEL A	SHEET 11

STANDARD MICROCIRCUIT DRAWING BULLETIN

DATE: 01-03-30

Approved sources of supply for SMD 5962-89728 are listed below for immediate acquisition information only and shall be added to MIL-HDBK-103 and QML-38535 during the next revision. MIL-HDBK-103 and QML-38535 will be revised to include the addition or deletion of sources. The vendors listed below have agreed to this drawing and a certificate of compliance has been submitted to and accepted by DSCC-VA. This bulletin is superseded by the next dated revision of MIL-HDBK-103 and QML-38535.

Standard microcircuit drawing PIN <u>1/</u>	Vendor CAGE number	Vendor similar PIN <u>2/</u>
5962-8972801EA	24355	AD588SQ/883B
5962-89728012A	24355	AD588SE/883B
5962-8972802EA	24355	AD588TQ/883B
5962-89728022A	24355	AD588TE/883B

1/ The lead finish shown for each PIN representing a hermetic package is the most readily available from the manufacturer listed for that part. If the desired lead finish is not listed contact the vendor to determine its availability.

2/ Caution. Do not use this number for item acquisition. Items acquired to this number may not satisfy the performance requirements of this drawing.

Vendor CAGE number

24355

Vendor name and address

Analog Devices
 Route 1 Industrial Park
 P.O. Box 9106
 Norwood, MA 02062
 Point of contact: 804 Woburn Street
 Wilmington, MA 01887-3462

The information contained herein is disseminated for convenience only and the Government assumes no liability whatsoever for any inaccuracies in the information bulletin.